

BEARCAT
 **PUMPS**

600B
Crude Oil Pump

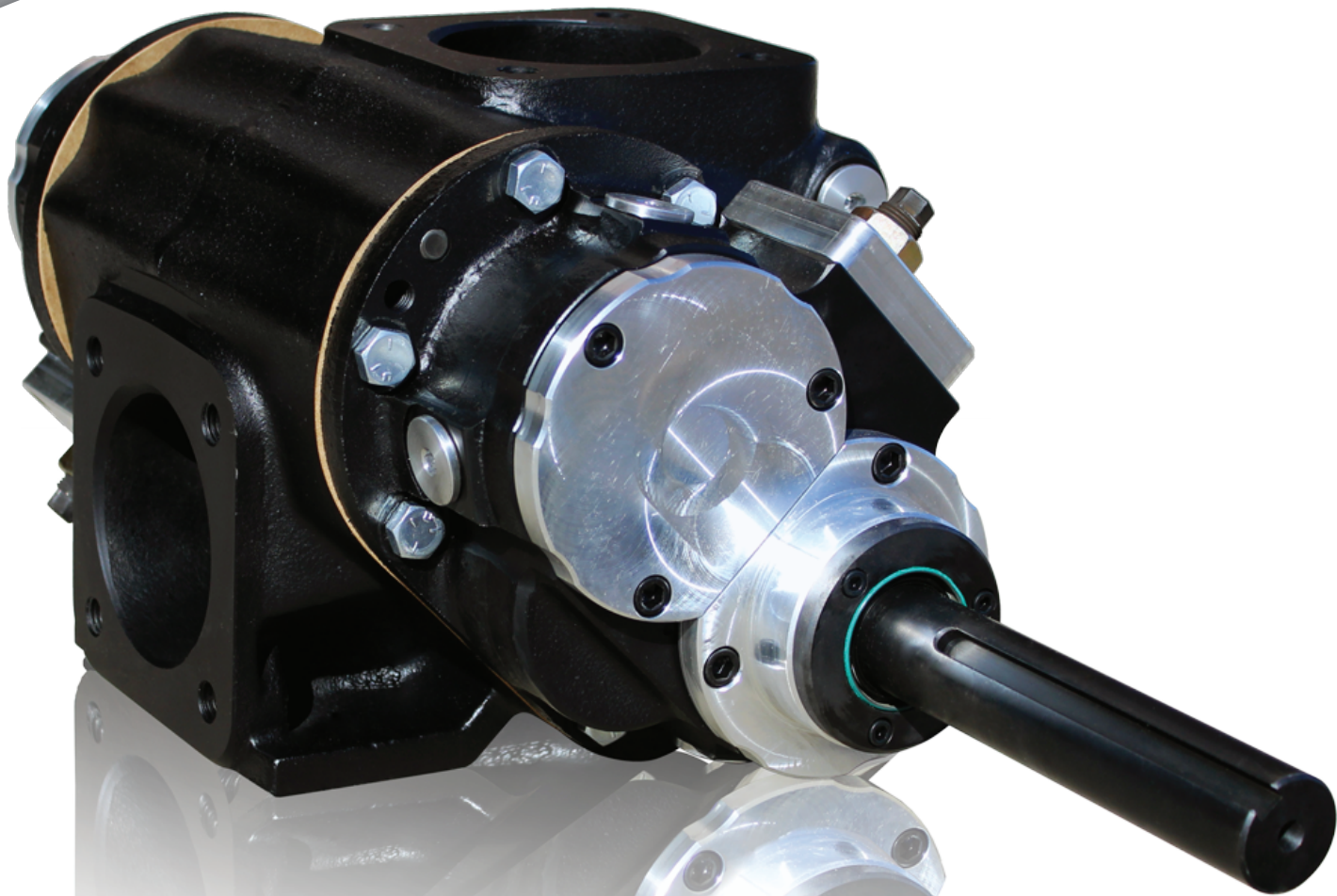

Compatible

Direct replacement on most transport trucks.

Productive

Large displacement to move more product.

Durable

The heat-treated gears, nitride-treated shafts, aluminum bronze bushings and ductile iron construction make the BearCat 600B a super long lasting pump.

1954 E. Deer Valley Rd. #103, Phoenix, AZ 85024 USA • 575-263-3338 • bearcatpumps.com

BEARCAT PUMPS



600B Crude Oil Pump

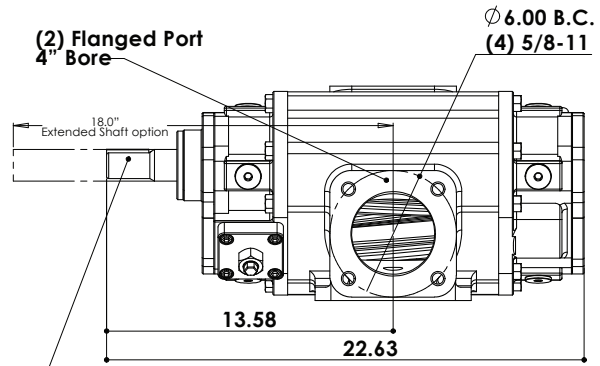
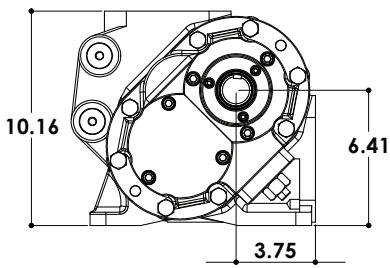
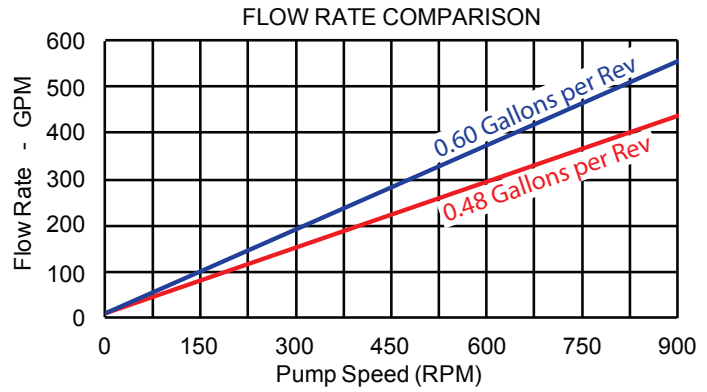
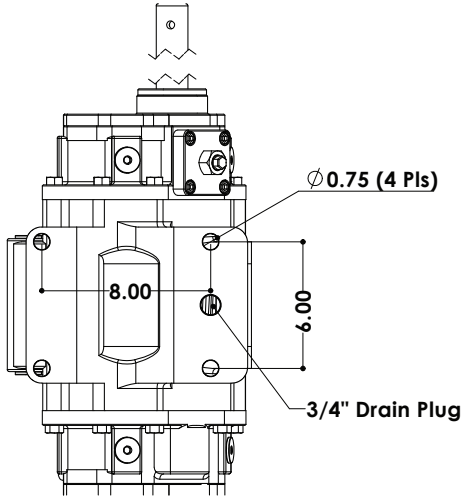

1-1/4" Dia with 1/4" Keyway
Can be supplied with 1-1/2" Extended Shaft 3/8" Keyway for PTO or Belt Drive systems



BEARCAT
PUMPS

- Pumps in stock
- Rebuildable
- Optional no-maintenance, no-leak lip seal
- Made in the USA